

**Permanent
Magnet LIFMA**

LPR-A series



The body is protected against impact with guards (used as handles also) on the front and the back. They also enable easy movement and positioning of the LIFMA.



- A smaller ON-OFF operating angle for easy operation. (Patent pending)

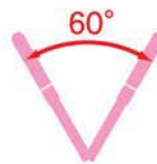

Full performance is exhibited in lifting such shape steel as H-shape and workpieces in small space.

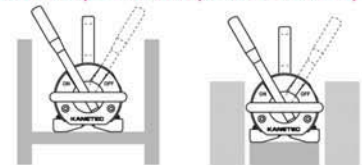

- The employment of a unique magnetic circuit enables handle lock by simple operation.

- A V-face best suited for lifting pipes and round steel responds to a wide range of diameters of workpieces.

The lifting capacity has been increased more than 50% from the conventional products. The employment of a round yoke has achieved both compactness & lightweight and holding power with margin & gap characteristics.

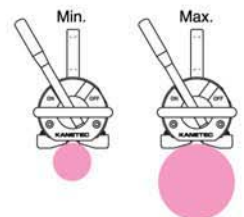

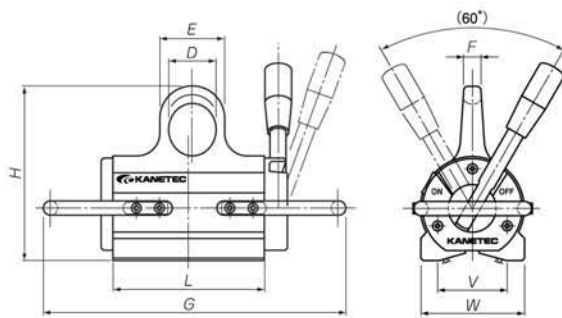

Specifications

[mm (in.)]

Model	Max. lifting capacity		Dimensions								Mass
	Steel plate workpiece	Round steel workpiece	W	V	L	H	G	D	E	F	
LPR-V150A	150kg 333 lb	100kg 222 lb	90 (3.54)	60 (2.36)	130 (5.11)	150 (5.90)	260 (10.2)	40 (1.57)	55 (2.16)	15 (0.59)	7.5kg 17 lb
LPR-V300A	300kg 666 lb	200kg 444 lb			230 (9.04)	165 (6.49)	360 (14.2)	50 (1.97)	70 (2.75)	20 (0.79)	12.5kg 28 lb
LPR-V600A	600kg 1332 lb	400kg 888 lb	136 (5.35)	90 (3.54)	270 (10.6)	225 (8.85)	440 (17.3)	60 (2.36)	90 (3.54)	25 (0.98)	35kg 78 lb
LPR-V1200A	1200kg 2664 lb	800kg 1776 lb	175 (6.88)	120 (4.72)	430 (16.9)	300 (11.8)	620 (24.4)	70 (2.75)	130 (5.11)	28 (1.10)	85kg 189 lb

※ The lifting capacity is indicated by one third (safety factor 3) of the maximum holding power.

Lifting Standard

Steel plate lifting standard (Flat steel plate ~)

[mm (in.)]

Thickness	Model			
	V150A	V300A	V600A	V1200A
t6	□900 (35.4) 450 (17.7) X 1500 (59.0)	□1200 (47.2) 500 (19.6) X 2500 (98.3)	□1300 (51.1) ※ 600 (23.6) X 2500 (98.3)	— ※
t12	□850 (33.4) 400 (15.7) X 1500 (59.0)	□1250 (49.1) 550 (21.6) X 2500 (98.3)	□1450 (56.9) 750 (29.4) X 2500 (98.3)	□1750 (68.7) ※ 900 (35.4) X 3000 (118.1)
t25	□650 (25.5) 260 (10.2) X 1500 (59.0)	□950 (37.3) 300 (11.8) X 2500 (98.3)	□1250 (49.1) 550 (21.6) X 2500 (98.3)	□1700 (66.9) 900 (35.4) X 3000 (118.1)
t50	□500 (19.6) 150 (5.9) X 1500 (59.0)	□700 (27.5) 250 (9.82) X 1800 (70.8)	□1000 (39.3) 350 (13.7) X 2500 (98.3)	□1400 (55.1) 600 (23.6) X 3000 (118.1)
t100	□350 (13.7) 150 (5.9) X 750 (29.4)	□550 (21.6) 250 (9.82) X 1100 (43.3)	□750 (29.4) 300 (11.8) X 1650 (64.8)	□1050 (41.2) 450 (17.7) X 2400 (94.3)

※ ... If the plate is thin, the handle operation becomes difficult.

Round steel lifting standard (Round steel ~)

[mm (in.)]

Round steel	Model			
	V150A	V300A	V600A	V1200A
Min.	φ75 (2.9) X 1400 (55.1) L	φ75 (2.9) X 2800 (110.1) L	φ100 (3.9) X 3000 (118.1) L	φ150 (5.9) X 3000 (118.1) L
Max.	φ200 (7.9) X 300 (11.8) L	φ300 (11.8) X 250 (9.8) L	φ400 (15.7) X 300 (11.8) L	φ450 (17.7) X 450 (17.7) L
Pipe permissible diameter ※	φ75 (2.9) ~ 200 (7.9)	φ75 (2.9) ~ 300 (11.8)	φ100 (3.9) ~ 500 (19.6)	φ150 (5.9) ~ 700 (27.5)

※ ... Note the capacity will vary according to pipe thickness.

It is dangerous to lift pipes that are oval or curved even if they are short.

The lifting capacity will vary according to diameters of round steel.

Do not lift workpieces longer than 3 m with a single unit. It is a dangerous practice.

At the maximum diameter, workpieces that are shorter than the attractive face cannot be lifted.

※ This Standard table has been created as a guide for actual work and does not guarantee absolute safety.

The capacity may drop due to various factors not shown in the table. Consider every possible factor when using LIFMA.

Workpiece surface vs. holding power

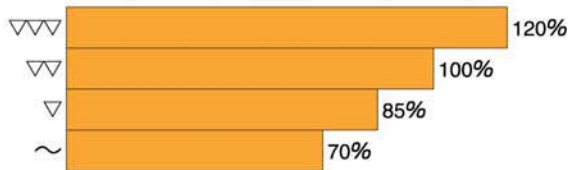

Relation between the steel plate thickness and the holding power

(Material SS400, surface roughness ▽▽)

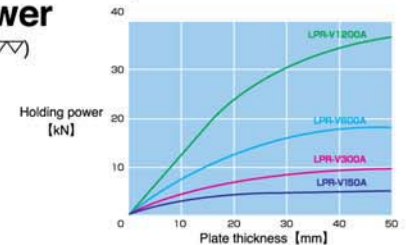
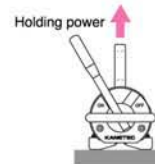

Workpiece material vs. holding power



Relation between the gap and the lifting capacity

The relation between the gap and the lifting capacity is as shown below. (Material SS400, thickness 50 mm, surface roughness ▽▽)

